



The robust, efficient and flexible design of the EuroCarrier makes it one of the best vessels for anchor handling, dredging support and survey activities. The EuroCarrier can be adapted to perfectly fit any project within a short time.

EuroCarrier 2209 | Neptun Viking

GENERAL	
IMO NR.	9844227
CALL SIGN	PDBS
YEAR BUILT	2018
HOME PORT	Aalst
YACHT NUMBER	NP 498
CLASSIFICATION	Bureau Veritas I  HULL • MACH Unrestricted Navigation, Multi-Purpose Ship / Special Service GMDSS Area A1

DIMENSIONS	
LENGTH O.A.	21,60 meter
BREADTH MLD.	9,04 meter
DEPTH AT SIDE	2,80/3,00 meter
DRAFT	2,00 meter
GROSS TONNAGE	135 ton
NET TONNAGE	40 ton
PERFORMANCES	
SPEED	9 knots
BOLLARD PULL	15,5 ton
PROPULSION	
MAIN ENGINES	2x Caterpillar C18
TOTAL POWER	2x 477 kW at 1800 RPM
PROPELLERS	1350 mm diameter in nozzle
AUXILIARIES	
GENERATOR SETS	2x Caterpillar C4.4 1 radiator cooled, 1 box cooled
TOTAL E-POWER	107 KvA + 103 KvA
HYDRAULIC POWER PACK	2x 55 kW - Electrical driven
BOWTHRUSTER	80 kW
ACCOMMODATION	
FACILITIES	Airconditioned accommodation for up to 4 persons

TANKS	
FUEL OIL	56 m ³
FRESH WATER	59 m ³
DECK LAY-OUT	
ANCHOR HANDLING WINCH	split drum type
PULLING FORCE	50 tons at 1 st layer
HAULING SPEED	10m/min- 30m/min
PULLING FORCE	10 tons at 1 st layer
TUGGER WINCH	Single drum type
DECK CRANE FORWARD	Eiffer 145000- 3S
DECK	Azobé deck covering
TOWING HOOK	Mampaey 20 tons SWL
TOWING PINS	Fore ship set towing pins manual
FENDERING	Tire fendering at sides, pushbow fendering fore- and aft ship
BOWTHRUSTERS	

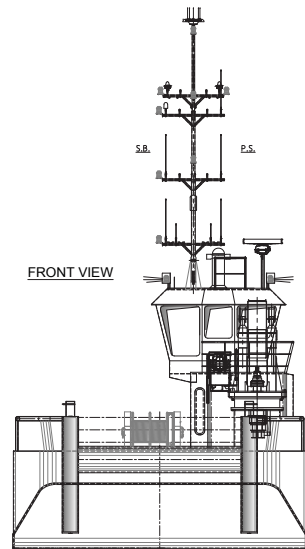
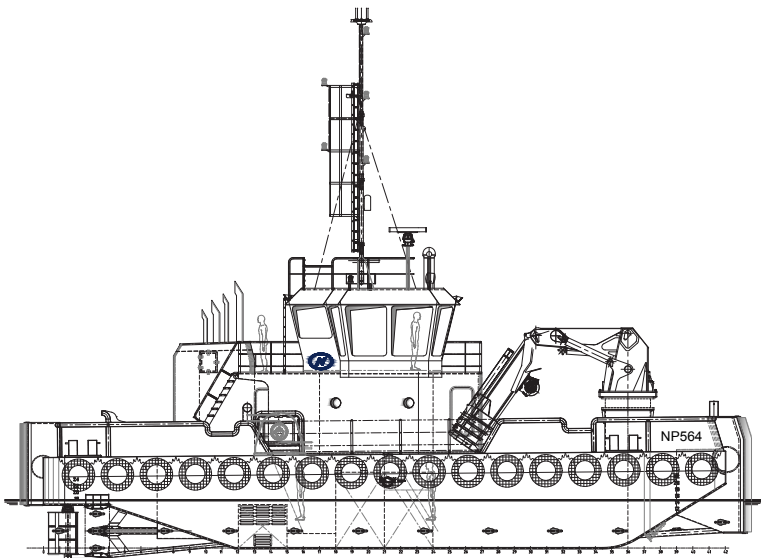

FRONT VIEW

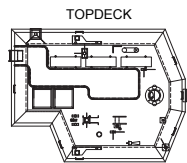

TOPDECK

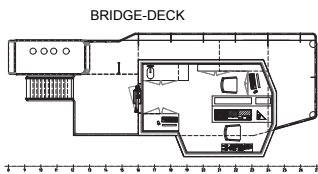

BRIDGE-DECK

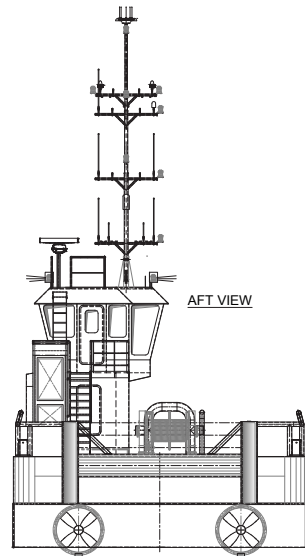

AFT VIEW

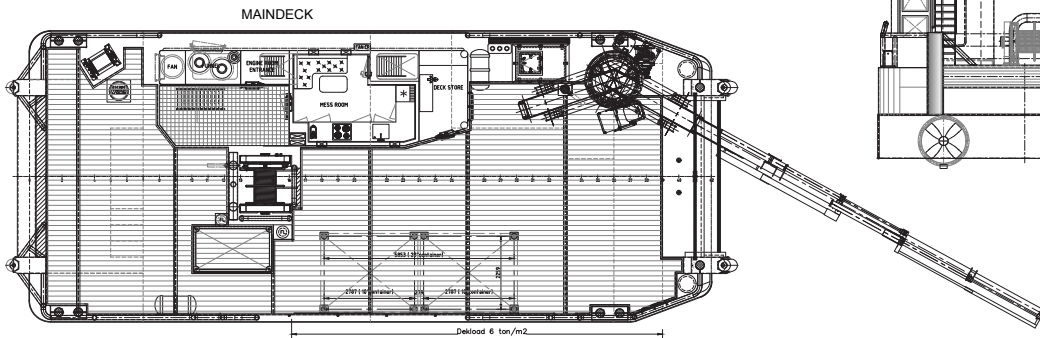

MAINDECK

Deckload 6 ton/m²

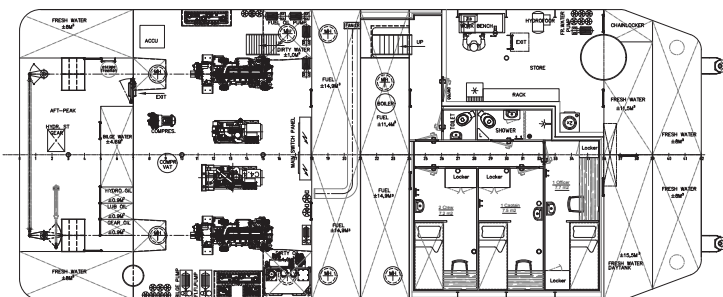

EuroCarrier 2209 | Neptun Viking

For more information, please contact us on:

T +31 (0)184 621 423 E info@neptunmarine.com W www.neptunmarine.com

Version: V.02

