

LGMG

AR20J

ARTICULATING BOOM LIFT



- 260/350kg (573 lbs/772 lbs) dual-capacity design, 2.44m (8') triple entry platform.
- Oscillating, full-time floating axels allow the wheels to grip to the ground when driving on hard, uneven terrain.
- Integrated four-wheel-drive system provides strong power, smooth transmission, and 45% gradeability.
- Equipped with three steering modes: four-wheel steering, crab steering, and front-wheel steering, and equipped with one-touch wheel alignment.
- Proportional lift and drive controls deliver smoother maneuvering, precise positioning and comfortable operation.

LGMG Diesel - Articulating Boom Lift

SPECIFICATIONS

MODELS	AR20J (AR65J)	
	Metric	Imperial
Measurements		
Work Height Max.	21.58m	70'10"
Platform Height Max.	19.58m	64'3"
Horizontal Outreach	12.37m	40'7"
Up and Over Height	8.19m	26'10"
Platform Length	2.44m	8'
Platform Width	0.9m	2'11"
Ⓐ Stowed Length	9.42m	30'11"
Length-Transport (jib tucked)	7.63m	25'
Ⓑ Overall Width	2.5m	8'2"
Ⓒ Stowed Height	2.46m	8'1"
Height-Transport	2.96m	9'9"
Ⓓ Wheelbase	2.51m	8'3"
Ⓔ Ground Clearance	0.4m	1'4"

PRODUCTIVITY

Max. Platform Occupancy	2(unrestricted) / 3(restricted)	
Platform Capacity	260/350kg	573/772 lbs
Turntable Rotation	360°	360°
Drive Speed-Stowed	5km/h	3.1mph
Drive Speed-Raised	0.8km/h	0.5mph
Gradeability	45%	45%
Max. Wind Speed	12.5m/s	28mph
Turning Radius-Inside	1.9m	6'3"
Turning Radius-Outside	3.9m	12'10"
Max.Slope	4°/4°	4°/4°
Tires Type	RT Foam-filled	
Tires Size	355/55D625	

POWER

Power Source	Kubota V2403	
Fuel Tank Capacity	65L	17.2gal

HYDRAULIC SYSTEM

Hydraulic Oil Volume	100L	26.4gal
----------------------	------	---------

WEIGHT

Machine Weight (CE/ANSI)	9850kg	21715 lbs
--------------------------	--------	-----------

STANDARD FEATURES

Proportional control	Emergency stop device
Horn/Hour meter	Auto-leveling platform
Full-height drive	Anti-collision protection
Flashing beacons	Over tilt protection system
Cylinder bellows	Platform control cover
Oscillating axle	Overload sensing system
Platform tool box	Intelligent diagnostic system
Telematics connector	RT Foam-filled tires

OPTIONAL

Telematics	Solid tires
AC power to platform	Solid non-marking tires
Hydraulic generator kit	Foam-filled non-marking tires
Cold weather package	Half-height mesh platform
3.5kw Hydraulic generator	Biodegradable hydraulic oil
Auxiliary rail	

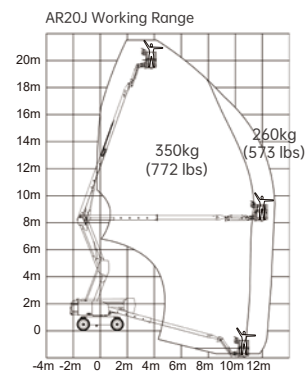
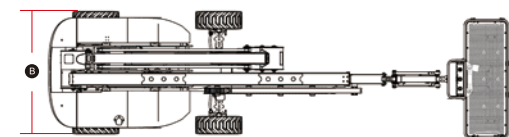
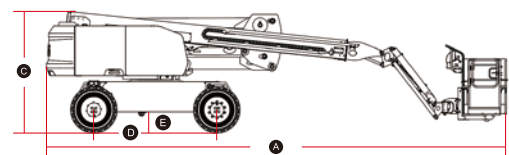

Please contact LGMG or a local dealer for more details.

LGMG reserves the right to change technical data without prior notice. All photos and pictures in this brochure are for promotional purposes only.

This brochure comes into effect in May, 2023.

LINGONG HEAVY MACHINERY CO., LTD.

Address: No. 2676, Kejia Road, Jinan, Shandong, China
 Email: sales@lmgm.com.cn Tel: +86 531 6787 9283

LGMG Europe B.V.

Address: Donker Duyvisweg 301, 3316 BL Dordrecht, The Netherlands
 Email: sales@lmggeurope.com Tel: +31 850 642 777

LGMG North America Inc.

Address: 4105 Live Oak Drive, Suite 100, The Colony, Texas 75056 United States
 Email: sales@lmgmna.com Tel: +1 833 288 5464

www.lmgmlifts.com



LGMG
 RELIABILITY IN ACTION